

**ADVANCED
NAVIGATION**

Air Data Unit Reference Manual





Table of Contents

1	Revision History.....	3
2	Firmware Changelog.....	4
3	Hardware Changelog.....	5
4	Introduction.....	6
5	Part Numbers and Ordering Information.....	7
5.1	Kit (with breakout cable).....	7
5.2	Standalone Unit.....	7
5.3	Accessories.....	7
6	Specifications.....	8
6.1	Mechanical Drawings.....	8
6.2	Sensors.....	9
6.3	Communication.....	9
6.4	Hardware.....	10
6.5	Connector Pin-out.....	10
6.6	Optional Breakout Cable.....	12
7	Installation.....	13
7.1	Position.....	13
7.2	Pitot Source.....	14
7.3	Static Source.....	14
8	Operation.....	15
8.1	Use standalone or with third party equipment.....	15
8.2	Use with Advanced Navigation Spatial series GPS/INS.....	15
8.2.1	Connection.....	16
8.2.2	Software Configuration.....	16
9	Advanced Navigation Packet Protocol.....	18
9.1	Data Types.....	18
9.2	Packet Structure.....	18
9.2.1	Header LRC.....	19
9.2.2	Packet ID.....	19
9.2.3	Packet Length.....	19
9.2.4	CRC.....	19
9.3	Packet Requests.....	19
9.4	Packet Acknowledgement.....	19
9.5	Packet Rates.....	20
9.6	Packet Summary.....	20
9.7	State Packets.....	20
9.7.1	Raw Sensors Packet.....	20
9.7.1.1	Raw Sensors Status.....	21
9.7.2	Air Data Packet.....	21
9.7.2.1	Air Data Status.....	21
9.7.2.2	Notes.....	22
9.8	System Packets.....	22
9.8.1	Acknowledge Packet.....	22
9.8.1.1	Acknowledge Result.....	22
9.8.2	Request Packet.....	22
9.8.3	Boot Mode Packet.....	23
9.8.3.1	Boot Mode Types.....	23
9.8.4	Device Information Packet.....	23
9.8.4.1	Device ID.....	24



9.8.5 Reset Packet.....24



1 Revision History

Version	Date	Changes
1.6	09/03/2022	Updated cable specification, section 6.5 Added Device ID Table, section 9.8.4.1 Added ODU connector pin location diagram, section 6.5
1.5	13/10/2020	Updated firmware changelog, section 2 Updated sensors section 6.2 Updated hardware section 6.4 Updated part numbers and ordering section 5
1.4	10/05/2019	Updated packet summary section 9.6 Updated sensors section 6.2
1.3	24/01/2018	Updated firmware changelog, section 2 Updated raw sensors packet, section 9.7.1
1.2	29/04/2016	Updated error in pinout table of section 6.6
1.1	14/09/2015	Added raw sensors packet, section 9.7.1
1.0	16/06/2015	Initial Release

Table 1: Revision history



2 Firmware Changelog

Version	Date	Changes
1.5	06/08/2020	Calibration improvements to increase accuracy
1.4	04/01/2018	Updated raw sensors packet to include temperature
1.1	14/09/2015	Added raw sensors packet output
1.0	02/03/2015	Initial Release

Table 2: Firmware changelog



3 Hardware Changelog

Version	Date	Changes
1.0	17/12/2014	Initial Release

Table 3: Hardware changelog



4 Introduction

Advanced Navigation's Air Data Unit is used to measure pitot airspeed and barometric altitude in fixed wing aircraft. It features high accuracy temperature calibrated pitot and static air data sensors and outputs data over an RS232 serial data interface.

The pitot airspeed and barometric altitude is typically used to drive aircraft instruments and control systems. It can be used standalone or connected to one of Advanced Navigation's Spatial series of GPS/INS products for outstanding navigation accuracy in fixed wing aircraft when GNSS is not available.

The Air Data Unit is available in three different airspeed variants to suit a wide range of applications.

The Air Data Unit will provide outstanding results when mounted, configured and operated correctly. Please read through this manual carefully to ensure a successful outcome for your application.

If you have any questions please contact support@advancednavigation.com.



5 Part Numbers and Ordering Information

5.1 Kit (with breakout cable)

Part Number	Description	Notes
AD-UNIT-LS-WC	Air Data Unit (Low Speed Version) with cable	Air Data Unit (Low Speed Version) ODU plug with 2m of cable to D9 connector and DC socket, see section 6.6
AD-UNIT-WC	Air Data Unit with cable	Air Data Unit ODU plug with 2m of cable to D9 connector and DC socket, see section 6.6
AD-UNIT-HS-WC	Air Data Unit (High Speed Version) with cable	Air Data Unit (High Speed Version) ODU plug with 2m of cable to D9 connector and DC socket, see section 6.6

Table 4: Kit (unit with breakout cable) part numbers

5.2 Standalone Unit

Part Number	Description	Notes
AD-UNIT-LS	Air Data Unit (Low Speed Version)	Air Data Unit (Low Speed Version) No cables included
AD-UNIT	Air Data Unit	Air Data Unit No cables included
AD-UNIT-HS	Air Data Unit (High Speed Version)	Air Data Unit (High Speed Version) No cables included

Table 5: Standalone unit part numbers

5.3 Accessories

Part Number	Description	Notes
A503-SDC20761	Air Data Unit Breakout Cable	Air Data Unit ODU plug with 2m of cable to D9 connector and DC socket, see section 6.6
CABLE-FTDI	D9 RS232 / RS422 to USB cable 1 m	D9 RS232/RS422 to USB cable. For easy connection of Air Data Unit to computer
A503-SDC20740-2M	ODU plug with 2m cable (unterminated)	Air Data Unit ODU plug with 2m of unterminated cable, see section 6.5

Table 6: Accessories part numbers



6 Specifications

6.1 Mechanical Drawings

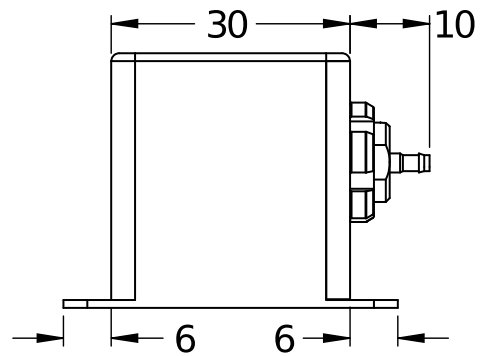
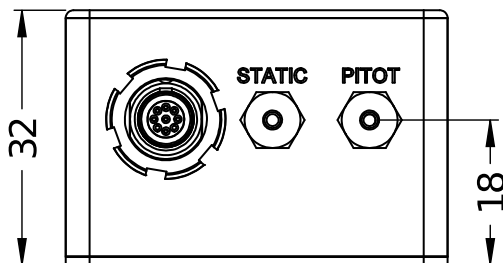
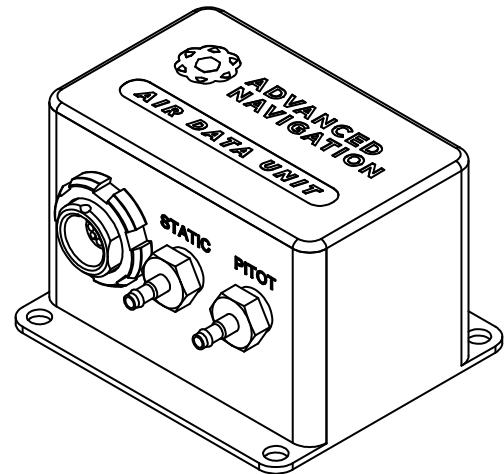
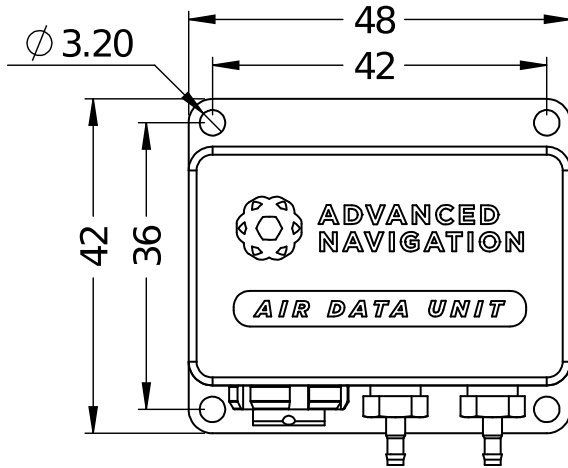

Illustration 1: Mechanical drawings of Air Data Unit



6.2 Sensors

Parameter	Value		
	Low Speed Variant	Standard Variant	High Speed Variant
Maximum Airspeed	63 m/s	225 m/s	420 m/s
Minimum Valid Airspeed	8.0 m/s	20 m/s	48 m/s
Airspeed Accuracy	0.5 m/s	1.0 m/s	2.0 m/s
Airspeed Resolution	0.00005 m/s		
Maximum Altitude	20,000 m		
Altitude Accuracy (turn on to turn on)	18 m		
Altitude Accuracy (in run)	1.0 m		
Altitude Resolution	0.0015 m		
Calibrated Temperature Range	-20 to 60 °C		
Burst Airspeed Pressure	34 kPa	103 kPa	310 kPa

Table 7: Sensor specifications

6.3 Communication

Parameter	Value
Interface	RS232
Interface Isolation	Optically Isolated
Speed	115200
Protocol	AN Packet Protocol
Output Data Rate	20 Hz

Table 8: Communication specifications



6.4 Hardware

Parameter	Value
Operating Voltage	5 to 36 V
Input Protection	±40 V
Power Consumption	15mA @ 5 V (typical)
Operating Temperature	-20 to 85 °C
Environmental Protection	IP67 MIL-STD-810G
Shock Limit	100 g
Pressure Barb Size	3mm
Dimensions	48x42x32 mm
Weight	55 grams

Table 9: Hardware specifications

6.5 Connector Pin-out

Power supply and signal connections are made through a ODU Mini-Snap Series B 9 pin connector (part number S30B0S-P09MCC0-5000). The connector provides a reliable and rugged connection to the Air Data Unit under demanding conditions and is rated to IP68 in the mated condition. Advanced Navigation stocks 2 metre unterminated ODU cables that are shielded and have external TPE insulation. Each individual wire is colour coded, FEP coated 28AWG wire, labelled with the ODU pin number on the unterminated end. Custom cable lengths can be ordered by request.

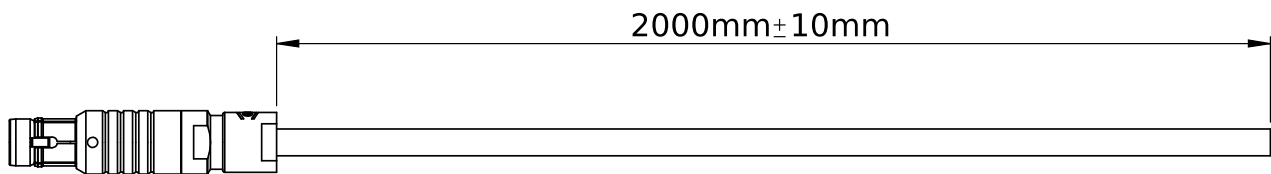

ODU MINI-SNAP SERIES B
(S30B0S-P09MCC0-5000)

Illustration 2: Air Data Unit plug with 2 metres of cable

See Illustration 3 for ODU connector pin locations and Table 10 for each pin function. Illustration 4 shows the perspective used for the pin location diagram.



PIN SIDE VIEW

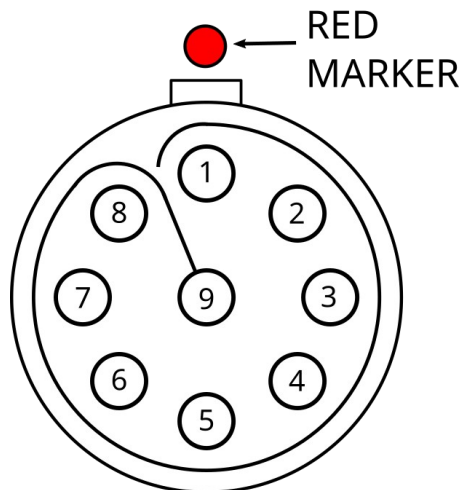

Illustration 3: ODU B series pin locations



Illustration 4: Pin-out view perspective

Pin	Colour	Function
1	Black	Signal Ground
2	Brown	Power Supply
3	White	
4	Green	
5	Red	RS232 Transmit
6	Orange	RS232 Receive
7	Yellow	
8	Blue	
9	Pink	Power Ground

Table 10: Connector pin allocation table



6.6 Optional Breakout Cable

Advanced Navigation offers a pre-terminated breakout cable fitted with industry standard connectors. The breakout cable is 2 metres long with the RS232 port expressed on a standard DSUB9 connector and power on a DC jack, please see Illustration 5.

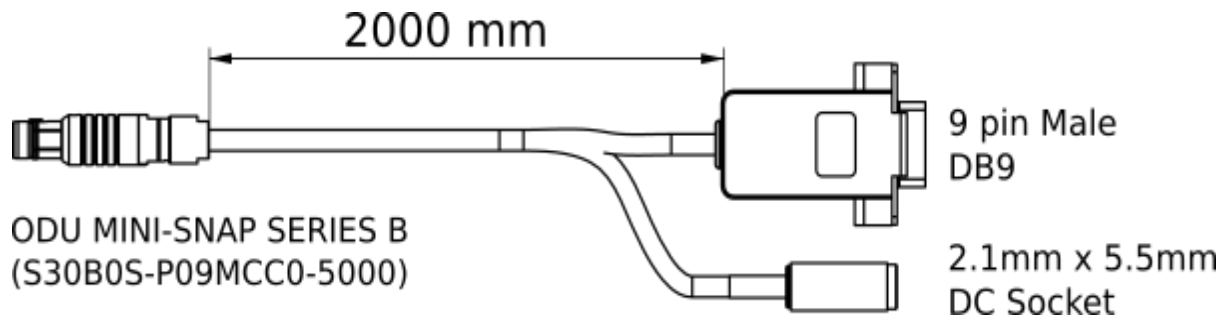

Illustration 5: Air Data Unit breakout cable

Pin	Colour	Function	DB9 Pin	Power
1	Black	Signal Ground	5	
2	Brown	Power		Tip
3	White			
4	Green			
5	Red	RS232 Transmit	3	
6	Orange	RS232 Receive	2	
7	Yellow			
8	Blue			
9	Pink	Power Ground		Ring

Table 11: Optional breakout cable connector pin-out



7 Installation

7.1 Position

It is recommended to install the air data unit in a position that is within 2 metres of the pitot tube and static vent. Please see Illustration 6 for example positioning in a UAV with a pitot tube that has integral static vents. Nylon tubing with an inside diameter of 2.4 mm is recommended for use with the Air Data Unit.

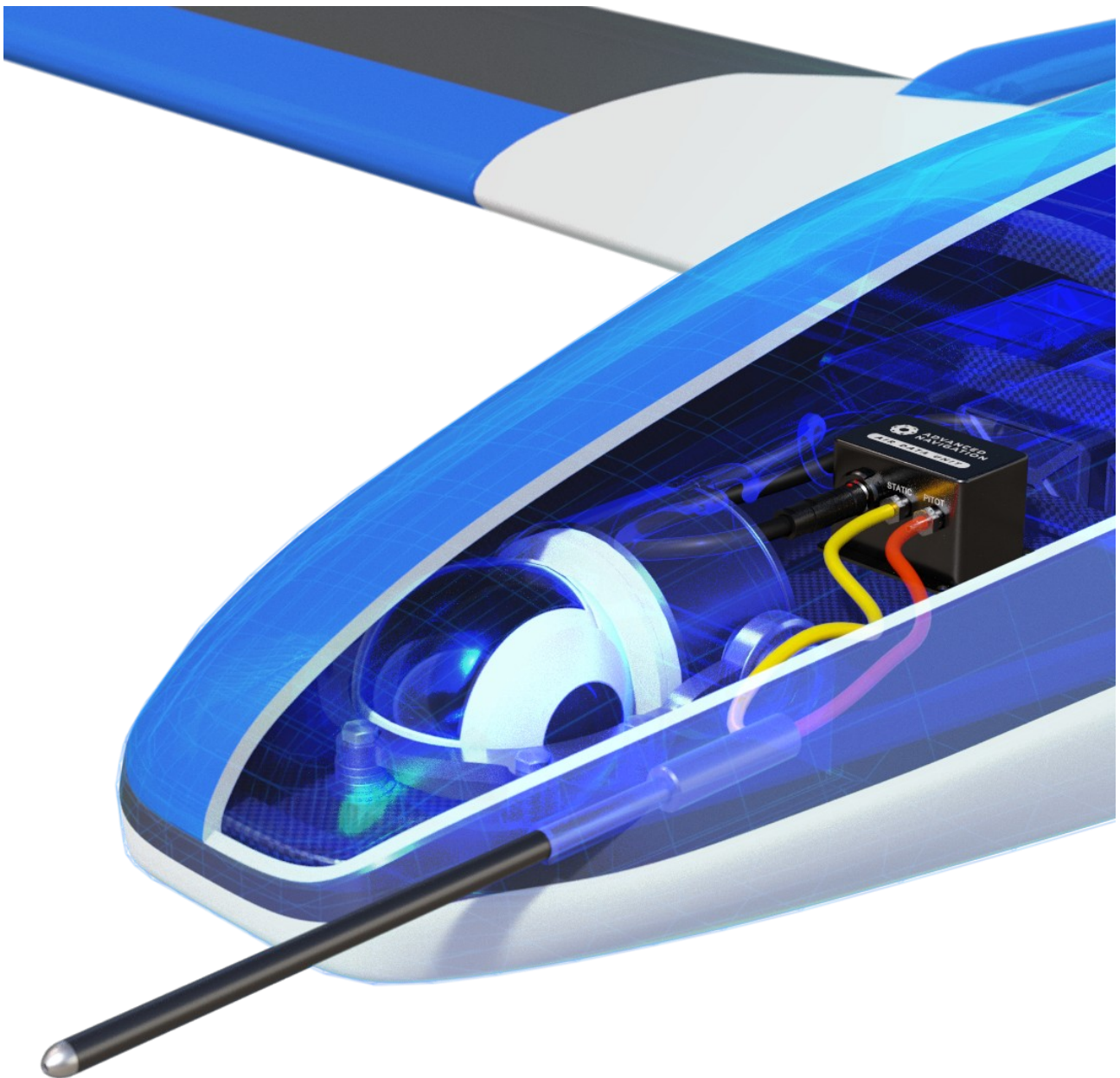

Illustration 6: Example air data unit installation



7.2 Pitot Source

It is recommended to use a pitot tube with an inside diameter of 1.5mm or higher. The pitot tube needs to be mounted such that the tip is outside of turbulent air flow. Typically the best mounting points are projecting forwards of the nose of the aircraft or projecting forwards from the wing.

7.3 Static Source

The static source may either be integrated into the pitot tube or joined flush vents on alternate sides of the fuselage. The location should be chosen such that the vents are outside of turbulent air flow.



8 Operation

8.1 Use standalone or with third party equipment

The Air Data Unit can be used standalone or integrated with third party equipment. Advanced Navigation supplies a royalty free SDK that can be used to quickly and easily integrate the unit.

The Air Data Unit can be connected to a computer using a null modem RS232 cable and a USB to RS232 adapter. These are not supplied as standard with the Air Data Unit.

Advanced Navigation also supplies a basic software utility called Air Data Unit Viewer that can be used to display the output from the Air Data Unit. Air Data Unit Viewer can be downloaded from the software section of the Air Data Unit page on the Advanced Navigation website. Java software must be installed to run this utility. Java can be downloaded from the Java website at this address: <http://www.java.com>. Illustration 7 shows a screenshot of the Air Data Unit Viewer.

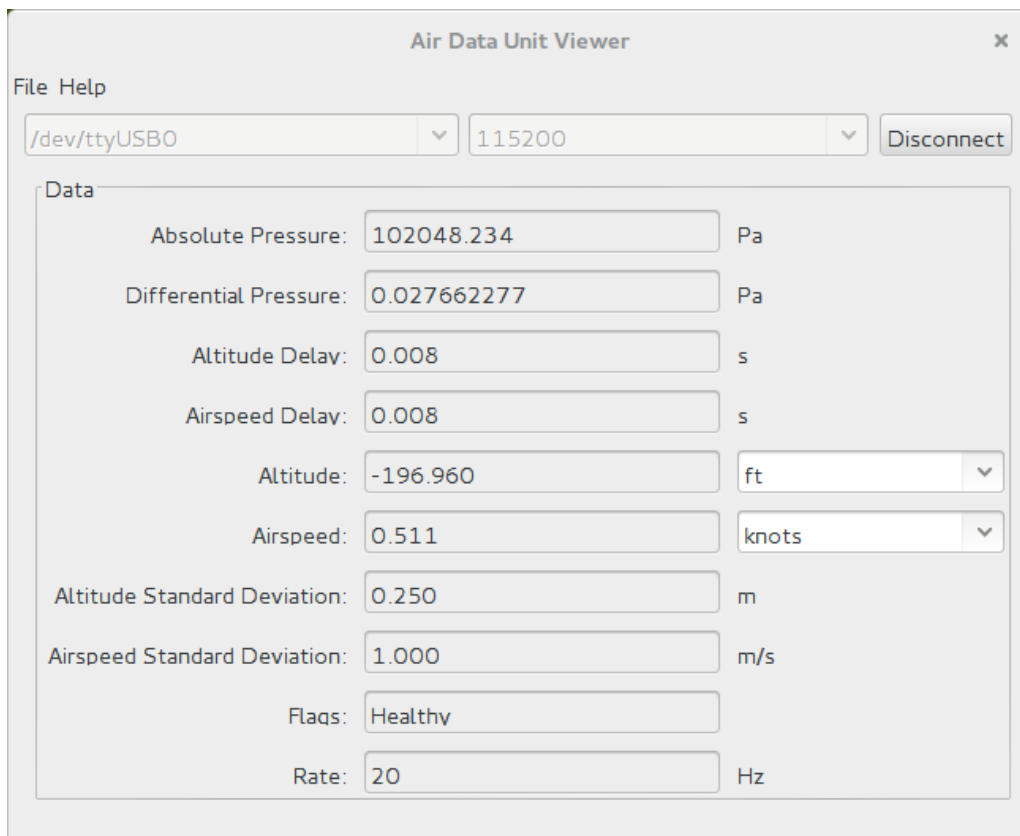

Illustration 7: Air Data Unit Viewer screenshot

8.2 Use with Advanced Navigation Spatial series GPS/INS

All Advanced Navigation's Spatial series of GPS/INS products support the Air Data Unit. To connect and set it up please follow the instructions below.



8.2.1 Connection

The Air Data Unit can be connected directly to a Spatial Dual or Spatial FOG with the standard interface breakout cable included in the evaluation kit. To use the Air Data Unit with Spatial an interface breakout cable needs to be purchased which is not included in the standard evaluation kit. The Air Data Unit should be plugged into the Auxiliary RS232 connector of the interface breakout cable, see Illustration 8.



Illustration 8: Air Data Unit connected to Spatial

8.2.2 Software Configuration

Use the following steps to setup a Spatial series device for use with the Air Data Unit.

1. Open Spatial Manager and connect to the Spatial device. See Step 1 in Illustration 9 below.
2. In the configuration menu, open the GPIOs dialogue, set the Auxiliary RS232 Function to ANPP Input and save. See Step 2 in Illustration 9 below.
3. In the configuration menu, open the Baud Rates dialogue, set the Auxiliary Port Baud Rate to 115200 and save. See Step 3 in Illustration 9 below.
4. To verify that the system is functioning correctly, in the view menu, open the Status dialogue. Ensure the Spatial device is initialised. Power on the Air Data Unit and apply a slight pressure to the pitot port. After a few seconds the External Position and External Velocity status boxes should turn green. See Step 4 in Illustration 9 below.

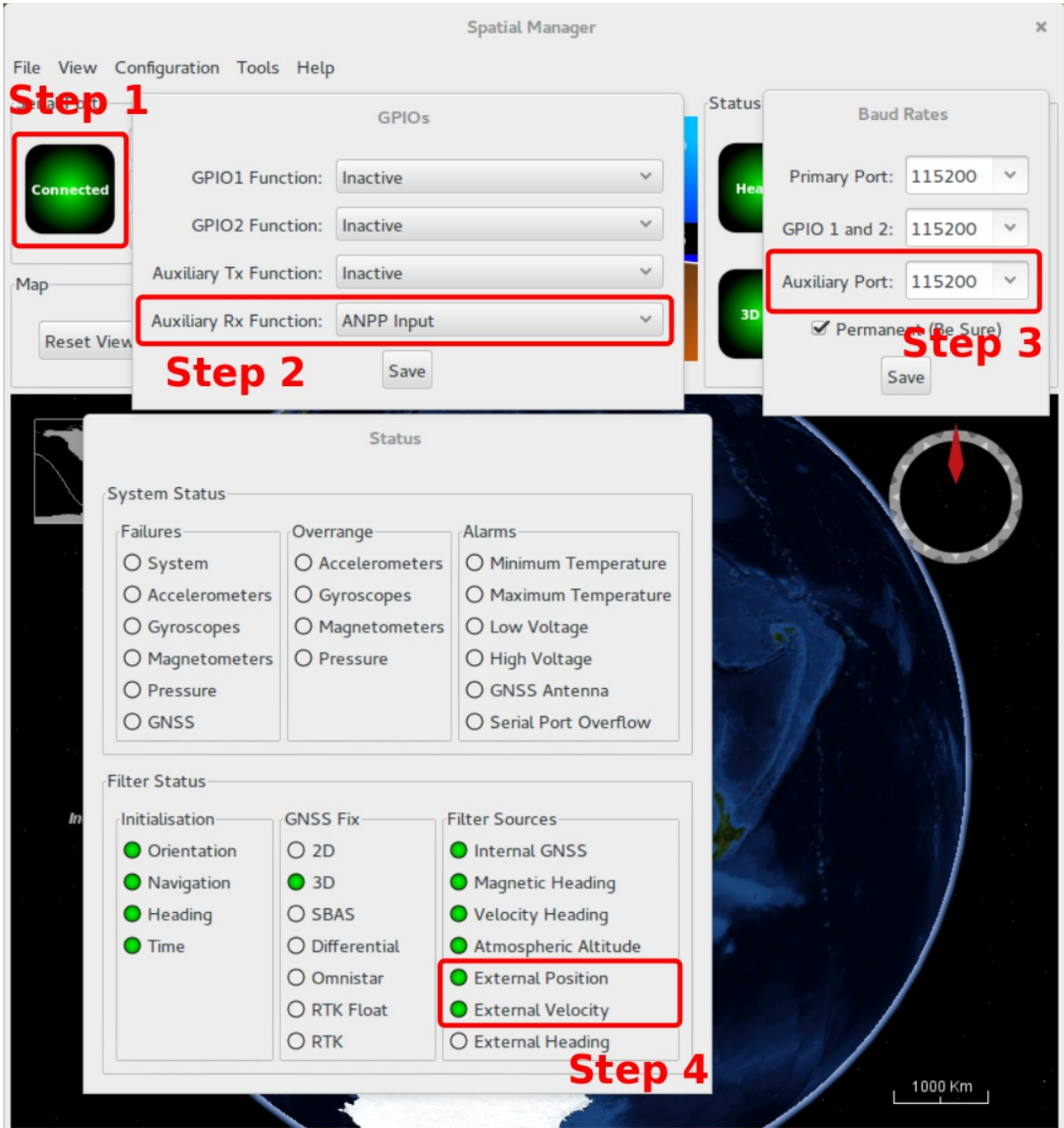

Illustration 9: Spatial Manager configuration steps

It is recommended to update your Spatial device to the latest firmware for best performance with the Air Data Unit.



9 Advanced Navigation Packet Protocol

All communication to the Air Data Unit is over the RS232 interface in the Advanced Navigation Packet Protocol (ANPP). The RS232 format is fixed at a baud rate of 115200, 1 start bit, 8 data bits, 1 stop bit, no parity and no flow control.

The Advanced Navigation Packet Protocol (ANPP) is a binary protocol designed with high error checking, high efficiency and safe design practices. It has a well defined specification and is very flexible. It is used across all existing and future Advanced Navigation products.

9.1 Data Types

The following data types are used in the packet protocol. All data types in the protocol are little endian byte ordering.

Abbreviation	Bytes	Also known as
u8	1	unsigned char, unsigned byte, uint8_t
s8	1	char, byte, int8_t
u16	2	unsigned short, uint16_t
s16	2	short, int16_t
u32	4	unsigned int, unsigned long, uint32_t
s32	4	int, long, int32_t
u64	8	unsigned long long, uint64_t
s64	8	long long, int64_t
fp32	4	float
fp64	8	double

Table 12: Data type abbreviations used in the ANPP

9.2 Packet Structure

The ANPP packet structure is shown in Table 13 and the header format is shown in Table 14. Example code can be downloaded from the software section.

Header				
Header LRC	Packet ID	Packet Length	CRC16	Packet Data

Table 13: ANPP Packet Structure



ANPP Header Format				
Field #	Bytes Offset	Data Type	Size	Description
1	0	u8	1	Header LRC, see section 9.2.1
2	1	u8	1	Packet ID, see section 9.2.2
3	2	u8	1	Packet Length, see section 9.2.3
4	3	u16	2	CRC16, see section 9.2.4

Table 14: ANPP header format

9.2.1 Header LRC

The header LRC (Longitudinal Redundancy Check) provides error checking on the packet header. It also allows the decoder to find the start of a packet by scanning for a valid LRC. The LRC can be found using the following:

$$\text{LRC} = ((\text{packet_id} + \text{packet_length} + \text{crc}[0] + \text{crc}[1]) \wedge 0\text{xFF}) + 1$$

9.2.2 Packet ID

The packet ID is used to distinguish the contents of the packet. Packet IDs range from 0 to 255.

Within this range there are three different sub-ranges, these are system packets, state packets and configuration packets.

System packets have packet IDs in the range 0 to 19. These packets are implemented the same by every device using ANPP.

State packets are packets that contain data that changes with time, i.e. temperature. State packets can be set to output at a certain rate. State packets are packet IDs in the range 20 to 179.

Configuration packets are used for reading and writing device configuration. Configuration packets are packet IDs in the range 180 to 255. The Air Data Unit does not have any configuration packets.

9.2.3 Packet Length

The packet length denotes the length of the packet data, i.e. from byte index 5 onwards inclusive. Packet length has a range of 0 – 255.

9.2.4 CRC

The CRC is a CRC16-CCITT. The starting value is 0xFFFF. The CRC covers only the packet data.

9.3 Packet Requests

Any of the state and configuration packets can be requested at any time using the request packet. See section 9.8.2.



9.4 Packet Acknowledgement

When configuration packets are sent to Spatial, it will reply with an acknowledgement packet that indicates whether the configuration change was successful or not. For details on the acknowledgement packet, see section 9.8.1.

9.5 Packet Rates

The packet rates are automatic and fixed on the Air Data Unit. The Raw Sensors Packet and Air Data Packet output at 20Hz in that order. No other packets will automatically output.

9.6 Packet Summary

Packet ID	Length	R/W	Name
System Packets			
0	4	R	Acknowledge Packet
1	-	W	Request Packet
2	1	R/W	Boot Mode Packet
3	24	R	Device Information Packet
5	4	W	Reset Packet
State Packets			
28	13	R	Raw Sensors Packet
68	25	R	Air Data Packet
Configuration Packets			

Table 15: Packet summary

9.7 State Packets

The Air Data Unit has only two state packets which are the Raw Sensors Packet and the Air Data Packet. The Raw Sensors Packet and the Air Data Packet output at a fixed rate of 20Hz in order of packet ID from low to high.

9.7.1 Raw Sensors Packet

Raw Sensors Packet				
Packet ID			28	
Length			13	
Field #	Bytes Offset	Data Type	Size	Description
1	0	fp32	4	Absolute Pressure (Pa)
2	4	fp32	4	Differential Pressure (Pa)
3	8	u8	1	Raw sensors status, see section 9.7.1.1



4	9	fp32	4	Temperature (C)
---	---	------	---	-----------------

Table 16: Raw sensors packet

9.7.1.1 Raw Sensors Status

Bit	Description
0	Absolute pressure valid
1	Differential pressure valid
2	Absolute pressure sensor over-range
3	Differential pressure sensor over-range
4	Absolute pressure sensor failure
5	Differential pressure sensor failure
6	Temperature sensor valid
7	Temperature sensor failure

Table 17: Raw sensors status

9.7.2 Air Data Packet

Air Data Packet				
Packet ID			68	
Length			25	
Field #	Bytes Offset	Data Type	Size	Description
1	0	fp32	4	Barometric altitude delay (s)
2	4	fp32	4	Airspeed delay (s)
3	8	fp32	4	Barometric altitude (m)
4	12	fp32	4	Airspeed (m/s)
5	16	fp32	4	Barometric altitude standard deviation (m)
6	20	fp32	4	Airspeed standard deviation (m/s)
7	24	u8	1	Air data status, see section 9.7.2.1

Table 18: Air data packet

9.7.2.1 Air Data Status

Bit	Description
0	Barometric altitude valid
1	Airspeed valid
2	Barometric altitude sensor over-range



3	Airspeed sensor over-range
4	Barometric altitude sensor failure
5	Airspeed sensor failure
6-7	Reserved (set to zero)

Table 19: Air data status

9.7.2.2 Notes

QNH is defined as 101,325 Pascals for barometric altitude.

9.8 System Packets

9.8.1 Acknowledge Packet

Acknowledgement Packet				
Packet ID			0	
Length			4	
Field #	Bytes Offset	Data Type	Size	Description
1	0	u8	1	Packet ID being acknowledged
2	1	u16	2	CRC of packet being acknowledged
3	3	u8	1	Acknowledge Result, see section 9.8.1.1

Table 20: Acknowledge packet

9.8.1.1 Acknowledge Result

Value	Description
0	Acknowledge success
1	Acknowledge failure, CRC error
2	Acknowledge failure, packet size incorrect
3	Acknowledge failure, values outside of valid ranges
4	Acknowledge failure, system flash memory failure
5	Acknowledge failure, system not ready
6	Acknowledge failure, unknown packet

Table 21: Acknowledge result



9.8.2 Request Packet

Request Packet				
Packet ID			1	
Length			1 x number of packets requested	
Field #	Bytes Offset	Data Type	Size	Description
1	0	u8	1	Packet ID requested
+				Field 1 repeats for additional packet requests

Table 22: Request packet

9.8.3 Boot Mode Packet

Boot Mode Packet				
Packet ID			2	
Length			1	
Field #	Bytes Offset	Data Type	Size	Description
1	0	u8	1	Boot mode, see section 9.8.3.1

Table 23: Boot mode packet

9.8.3.1 Boot Mode Types

Value	Description
0	Bootloader
1	Main Program

Table 24: Boot mode types

9.8.4 Device Information Packet

Device Information Packet				
Packet ID			3	
Length			24	
Field #	Bytes Offset	Data Type	Size	Description
1	0	u32	4	Software version
2	4	u32	4	Device ID, see 9.8.4.1
3	8	u32	4	Hardware revision
4	12	u32	4	Serial number part 1
5	16	u32	4	Serial number part 2



6	20	u32	4	Serial number part 3
---	----	-----	---	----------------------

Table 25: Device information packet

9.8.4.1 Device ID

Bit	Description
1	Spatial
4	Spatial FOG
5	Spatial Dual
11	Orientus >v3
13	Air Data Unit
14	Subsonus
16	Spatial FOG Dual
17	Motus
19	GNSS Compass
21	Subsonus Tag
22	Poseidon
26	Certus
27	Aries
28	Boreas D90

Table 26: Device ID



9.8.5 Reset Packet

Reset Packet				
Packet ID			5	
Length			4	
Field #	Bytes Offset	Data Type	Size	Description
1	0	u32	4	Verification Sequence (set to 0x21057A7E)

Table 27: Reset packet



Information in this document is provided solely in connection with Advanced Navigation products. Advanced Navigation reserves the right to make changes, corrections, modifications or improvements, to this document, and the products and services described herein at any time, without notice.

All Advanced Navigation products are sold pursuant to Advanced Navigation's terms and conditions of sale.

Purchasers are solely responsible for the choice, selection and use of the Advanced Navigation products and services described herein, and Advanced Navigation assumes no liability whatsoever relating to the choice, selection or use of the Advanced Navigation products and services described herein.

No license, express or implied, by estoppel or otherwise, to any intellectual property rights is granted under this document. If any part of this document refers to any third party products or services it shall not be deemed a license grant by Advanced Navigation for the use of such third party products or services, or any intellectual property contained therein or considered as a warranty covering the use in any manner whatsoever of such third party products or services or any intellectual property contained therein.

UNLESS OTHERWISE SET FORTH IN ADVANCED NAVIGATION'S TERMS AND CONDITIONS OF SALE ADVANCED NAVIGATION DISCLAIMS ANY EXPRESS OR IMPLIED WARRANTY WITH RESPECT TO THE USE AND/OR SALE OF ADVANCED NAVIGATION PRODUCTS INCLUDING WITHOUT LIMITATION IMPLIED WARRANTIES OF MERCHANTABILITY, FITNESS FOR A PARTICULAR PURPOSE (AND THEIR EQUIVALENTS UNDER THE LAWS OF ANY JURISDICTION), OR INFRINGEMENT OF ANY PATENT, COPYRIGHT OR OTHER INTELLECTUAL PROPERTY RIGHT.

UNLESS EXPRESSLY APPROVED IN WRITING BY TWO AUTHORIZED ADVANCED NAVIGATION REPRESENTATIVES, ADVANCED NAVIGATION PRODUCTS ARE NOT RECOMMENDED, AUTHORIZED OR WARRANTED FOR USE IN MILITARY, AIR CRAFT, SPACE, LIFE SAVING, OR LIFE SUSTAINING APPLICATIONS, NOR IN PRODUCTS OR SYSTEMS WHERE FAILURE OR MALFUNCTION MAY RESULT IN PERSONAL INJURY, DEATH, OR SEVERE PROPERTY OR ENVIRONMENTAL DAMAGE.

ADVANCED NAVIGATION PRODUCTS WHICH ARE NOT SPECIFIED AS "AUTOMOTIVE GRADE" MAY ONLY BE USED IN AUTOMOTIVE APPLICATIONS AT USER'S OWN RISK.

Resale of Advanced Navigation products with provisions different from the statements and/or technical features set forth in this document shall immediately void any warranty granted by Advanced Navigation for the Advanced Navigation product or service described herein and shall not create or extend in any manner whatsoever, any liability of Advanced Navigation.

Information in this document supersedes and replaces all information previously supplied.

© 2022 Advanced Navigation - All rights reserved